



QPJ-1 去皮机

QPJ-1 Skinning Machine



QPJ-1去皮机是一种工业用转鼓式去皮机，它吸取了国内外同类机型的结构优点，并对方便操作和延长带刀使用寿命方面进行了改进，它用于人工或自动进料。专利号：0022162.7。QPJ-1适用于鲱鱼、鲈鱼、白鲷、鳕鱼、鲛鱼、金枪鱼、沙丁鱼等多种鱼类的去皮加工或去皮下面筋加工。

主要结构特点及性能

- ※ 主要部件均为不锈钢或工程塑料制作，符合食品卫生要求。
- ※ 转鼓主轴和所有传动轴均采用滚动轴承，双重耐老化胶圈密封。
- ※ 塑料传送带的进料段设在升降支架上，手柄操作可使传送带和转鼓接触或脱离。
- ※ 刀轨架可向外翻转，带刀更换和上下刀轨拆装方便。
- ※ R404A环保型制冷剂，膨胀阀供液回油可靠。

QPJ-1 skinning machine is the industrial scale drum skinning machine . It absorbed the structural advantages from other similar machine abroad, and it makes the operation much more convenient and provides longer life for the band knife . It is designed for manual or automatic feeding. The applying patent No.is 0022162.7

QPJ-1 is used to skin or skin the fat of herring ,mackerel, yellow fin sole, rock sole, squid ,tuna, sardine and other fishes.

Features

- ※All the main parts are made from stainless steel or engineering plastic, thus according with the demands of the food hygiene.
- ※The main shafts of the drum and all the transmission shafts adopted ball bearing, double-sealed by agingresistent ring.
- ※The feeding part of the plastic piece conveyor belt is on the up-down rack,the operation handle made the conveyor belt and drum contact or uncontact.
- ※The knife guide carcass can turn over outwardly, the replacement of the band knife is convenient,and the instalment or uninstalment of the upper and lower knife guide is also convenient.
- ※R404a environmental refrigerant, Reliable liquid supply and suction of expansion valve.



外形尺寸图 Main Dimension of Skinning Machine

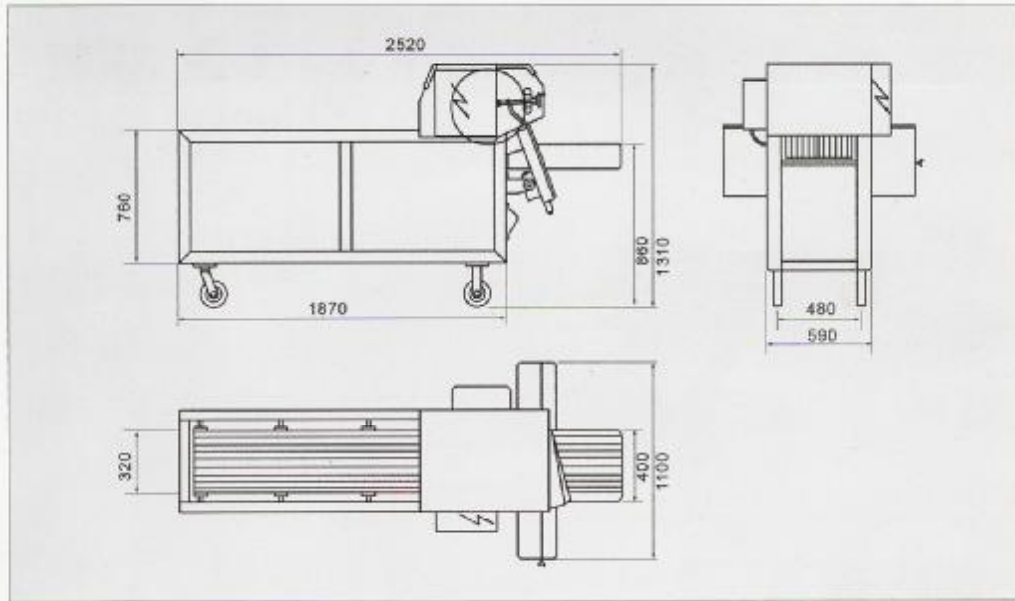

QPJ-1去皮机技术参数

电源 Electrical supply	总功率 Total power	额定功率 Rated power	耗水量 Water consumption	剥皮速度 Gas of hand mm/s	重量 Net weight
380V 50Hz AC 10%	6.05kW	R405A(或F22)和注量1kg	0.8L/min	240-350x0.3	100kg

※ 以上参数仅供参考，如有变更，恕不另行通知。

※The above parameters are only for your reference, if they are changed, we will not inform again, please forgive us.